



November 2006

DEDUCTIONS when using a CRANK GEARBOX

- **Keyway Tube** : Overall Width of Blind **LESS 75 mm**
- **Side Channel** : Overall Drop of Blind **LESS 102 mm**
- **Bottom Rail** with Slide Tongues : Overall Width of Blind **LESS 75 mm**
- **Bottom Rail** with Centre Lock * : Overall Width of Blind **LESS 60 mm**
- **Finished Skin Width** : Overall Width of Blind **LESS 75 mm**

* the 15mm Bottom Rail over hang goes on the Gearbox side

FINISHED SKIN CONSTRUCTION

Top of Finished Skin

- When using **63mm Keyway** : 3.6mm Spline
- When using **70mm Keyway** : 6mm Rope / Spline or 7.5mm Keder
- When using **78mm Keyway** : 6mm Rope / Spline or 7.5mm Keder
- **Bottom of Finished Skin** : 6mm Rope / Spline or 7.5mm Keder

Clear PVC Skin

Vertical Joints Only. Edges of Skin to be Strengthened by Sewing Or Welding a strip of Solid PVC

On Gearbox side - Skin sits 55mm inside the channel
On Pivot Pin & Plate side - Skin sits 70mm inside the channel

LOCKING



- **Locking Holes** : Drill 14mm or 16mm hole inside Channel for Slide Tongues OR Centre Lock

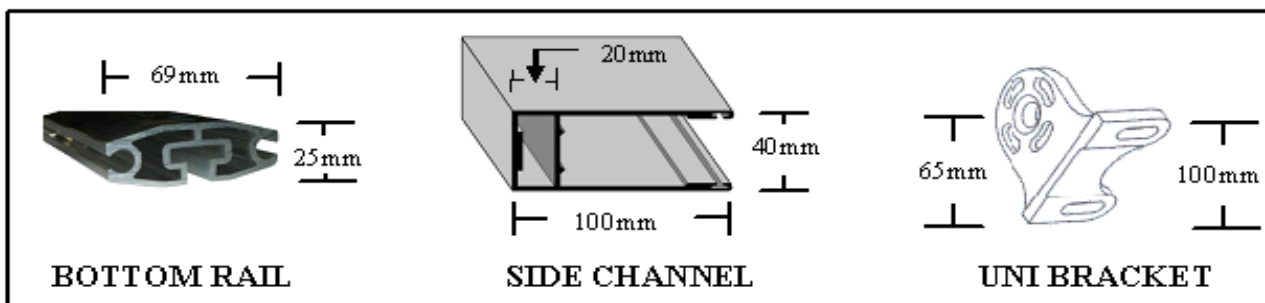

The above measurements are a recommendation. To be used as guide only